

Making Estimates in Research and Elsewhere

Lance Cooper



Q: How many cows can you fit in a barn?

A: *assume* spherical cows of radius $\sim R$
&
assume rectangular barn w/ volume $\sim L \times W$

$$N \sim (L \times W) / \pi R^2$$

Making Estimates in Research: Why?

It is the mark of an instructed mind to rest assured with that degree of precision that the nature of the subject admits, and not to seek exactness when only an approximation of the truth is possible.

- Aristotle

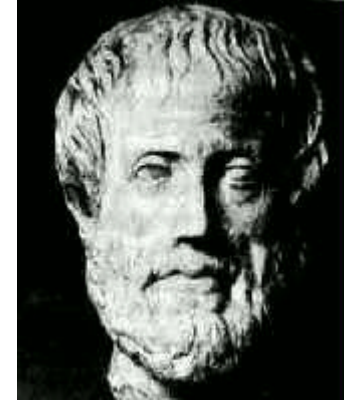

Why make estimates in science?

The ability to estimate – to within an order of magnitude or so – the size or probability of various quantities is useful in science as well as in many other endeavors:

To provide a rough check of more exact calculations

To provide a rough check of research results or hypotheses

To obtain estimates of quantities when other resources aren't available

To obtain estimates of quantities that are difficult to measure precisely

To obtain estimates of quantities for which no firm theoretical prediction exists
⇒ particularly important in interdisciplinary sciences, soft matter, astrophysics

To provide bounds for possible design alternatives

Making Estimates in Research: How?

How do you estimate the answer to a question that appears impossible to determine at all, or at least without access to an encyclopedia, internet connection, or omniscient being?

- e.g., how many grains of sand are there on earth's beaches?
- how many piano tuners are there in Chicago?
- how many atoms are in your body?

These problems are sometimes referred to as Fermi problems, after the physicist Enrico Fermi, who was famous for (among other things) posing and solving such problems.

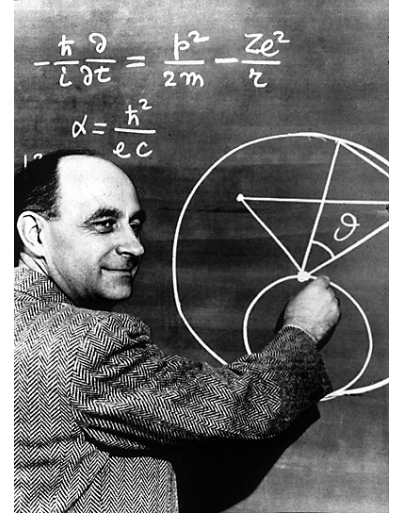

Enrico Fermi

Getting started:

- (1). Don't panic when you see the problem
- (2). Write down any fact you *do* know related to the question
- (3). Outline one or more possible procedures for determining the answer
- (4). List the things you'll need to know to answer the question
- (5). Keep track of your assumptions

Making Estimates in Research: How?

Other general guidelines for making order-of-magnitude estimates:

Make everything as simple as possible!

(1). Don't worry about specific values: round numbers to "convenient values"

e.g., $\pi \approx 3$; $8.4 \approx 10$; etc.

(2). Choose convenient geometries when modeling

e.g., a spherical cow, a cubic grain of sand, etc.

(3). Make "educated" guesses or even upper and lower bounds of quantities you don't know.

try to make good guesses, and keep track of these guesses, as they will set bounds on the fidelity of your estimate

(4). Use ratios when possible – by comparing the value of one quantity (e.g., force, energy, etc.) in comparison to a related quantity – in order to eliminate unknown parameters and get a dimensionless parameter

(5). If possible, exploit plausible scaling behavior of some quantity, i.e., estimate an unknown quantity by assuming it scales linearly - from known values – with some parameter

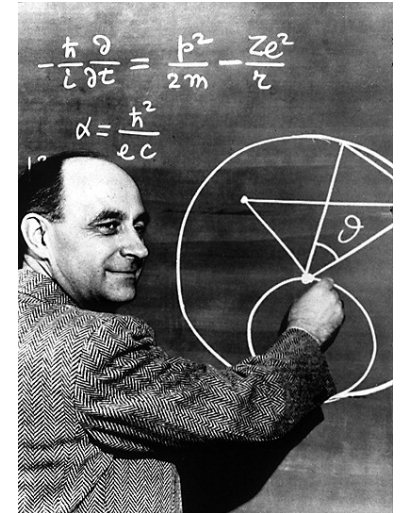

Making Estimates in Research: How?

More guidelines for making order-of-magnitude estimations:

Checking your estimates:

- (1). Make sure that your estimates and calculations are dimensionally correct! \Rightarrow This is a very powerful tool!
- (2). Check the plausibility of your estimate, if possible
e.g., if your answer exceeds the speed of light or the size of the universe, you've got a problem!
- (3). Check the plausibility of your estimate using an alternate calculation method
do the two methods agree to within an order of magnitude?
- (4). Perform a “reality check” on your estimate based on the number and size of the approximations you made
- (5). More quantitatively - place “bounds” on your estimate:
To obtain an “upper bound” – in equations, put largest estimated values of quantities in the numerator and the smallest estimated values in the denominator

To obtain a “lower bound” – in equations, put smallest estimated values of quantities in the numerator and the largest estimated values in the denominator

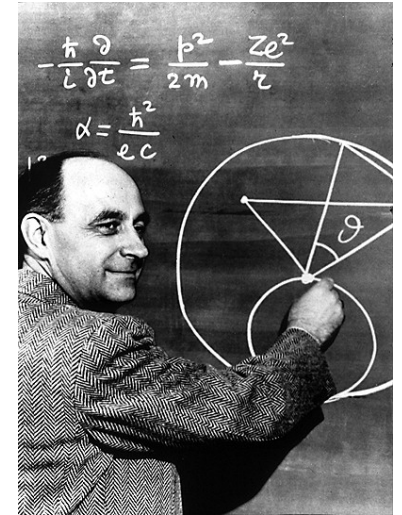

Making Estimates: Hairs on a Human Head

How many hairs on a human head?

(1). What do we need to know? Size of a typical scalp, and approximate number of hairs per square inch

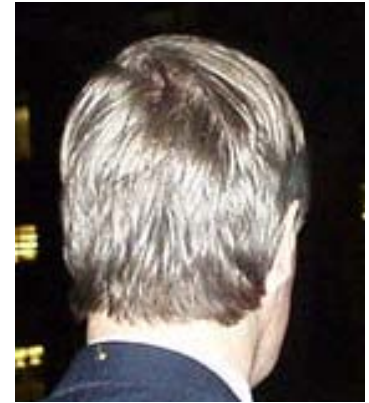

Hairs per inch: 20 – 40 (guess or measure) \Rightarrow 400 – 1600 per inch²

(2). Do we need a model? We don't want a precise, specific answer, so assume "average" head that is a hemisphere (keep it simple!)

Radius of "typical" head: \sim 5 inch (guess or measure)

\Rightarrow area of scalp $\sim \frac{1}{2}(4\pi r^2) \sim$ 150 inch² (you can take $\pi \sim 3!$ Excellent!)

(3). Make your estimate!

Note dimensional consistency!

of hairs \sim area of scalp * hairs/unit area \sim 60,000 – 240,000 hairs

OR $N \sim 10^5$ hairs

Rounding up is OK, even encouraged! \Rightarrow



(4). Now, check: How good were our approximations?

Chemistry Estimates: Atoms in a Grain

How many atoms in a grain of sand?



(1). What do we need to know? Size of a grain of sand, size of an atom

Dimension of a grain of sand: assume $L_{\text{sand}} \sim 1 \text{ mm} = 10^{-3} \text{ m} \times 10^{10} \text{ \AA/m} = 10^7 \text{ \AA}$

Dimension of an atom: assume $L_{\text{atom}} \sim 1 \text{ \AA}$

(2). Do we need a model? Don't worry about geometry...assume a cubic grain of sand!

Volume of grain of sand: $V_{\text{sand}} \sim (10^7)^3 \text{ \AA}^3 \sim 10^{21} \text{ \AA}^3$

Volume of an atom: $V_{\text{atom}} \sim (1)^3 \text{ \AA}^3 \sim 1 \text{ \AA}^3$

(3). Make your estimate!

of atoms in 1 grain \sim (volume of 1 grain)/(volume of 1 atom) $\sim 10^{21}$ atoms per grain

(4). Now, check: How good were our approximations?

Close to N_A ... so this is reasonable

“Musical” Estimates: Piano Tuners in CU

How many piano tuners are there in Champaign?

(Similar to an original Fermi problem!)



"Let me through - I'm a piano tuner!"

(1). What do we need to know? How many families are there in Champaign? How many families own a piano? How often are pianos tuned? How many tuners are needed?

of people in CU: Estimate 150,000

of families in CU: Estimate $150,000/4 \sim 38,000$

of families owning a piano: Estimate 1 in 10 $\Rightarrow \sim 4,000$ pianos in Champaign

rate at which pianos are tuned: Estimate 1 time each year $\Rightarrow \sim 4,000$ tunings/year

rate at which piano tuners can perform a tuning: Estimate ~ 4 tunings/day, working ~ 200 days/year (exclude weekends and holidays) $\Rightarrow \sim 800$ tunings/year per tuner

(2). Make your estimate!

of tuners \sim (rate at which piano tunings are needed)/(rate at which each tuner performs tunings)

$$\Rightarrow (4000 \text{ tunings/year}) / (800 \text{ tunings/year} \cdot \text{tuner}) \sim \boxed{5 \text{ tuners } (\pm 3 \text{ tuners})}$$

See Our Ad This Page

SAMUEL MUSIC
1006 W Anthony Dr Champgn-----352-2466

PIANOS-TUNING, REPAIR & REFINISH

BALDWIN MUSIC
28 E Springfield Av Champgn----- 352-7026

Also
CLUVER DENNIS PIANO SERVICE
1507 Grandview Dr Champgn-----355-2036

DEPPE JOHN
601 W High Urbana----- **344-2775**

PIANO PEOPLE THE
SEE OUR AD AT PIANOS
217 359-7601
503 S. Country Fair Dr Champaign

7-6683
9-2100
ROHDE TED PIANO TUNING & REPAIR
2263 County Rd 1700 N St Jos-- 469-7085

STEVE RASCH PIANO TUNING
COMMERCIAL & HOME ACCOUNTS
• Expert Regulation
To schedule an appointment call:
217 531-3413
Fax# 217-352-3398
CHAMPAIGN, IL

PRAIRIE
Readyma
3000 V
Champ

STARK EX
2000 N

Pin Ba
See Amu
Games &

STREHLOW CINDY
907 S Anderson Urbana-----328-2691

PICTURE FRAMES-DEALERS

From C/U Yellow Pages...

Estimate: 2-8

Actual: 7

Culinary Estimates: Supersize Me

How many McDonalds franchises are there in the US?



(1). What do we know? # of McDonalds in Champaign, population of Champaign, population of US

of McDonalds in Champaign: estimate $N_{\text{champaign}} \sim 6$

population of Champaign: $\sim 150,000$

population of US: $\sim 250,000,000$

\Rightarrow Reasonably assume that # of McDonalds franchises scales with population!

(2). Make your estimate!

Assume simple scaling relationship

$N_{\text{USA}} \sim (\text{population of US}/\text{population of Champaign}) * (\# \text{ of McDonalds in Champaign})$

$N_{\text{USA}} \sim 10,000$

Actual: 13,000

Technological Estimates: Storage Capacity of CDs

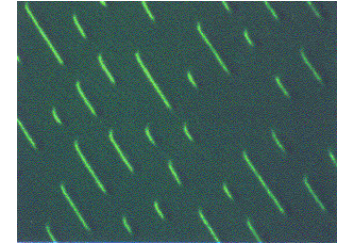

Introduction: CDs store information as a high density of “pits” or bumps in an aluminum layer

(a) How many “pits” in a typical CD, and what is their spacing?

(1). What do we need to know for (a)? Active area of CD, storage capacity of CD

Consider 700 Mbyte CD \Rightarrow (8 bits = 1 byte) 700 Mbytes = 5.6×10^9 bits! \leftarrow # of pits!

To get the pit spacing, we need to estimate the active area on the CD:

$$A_{CD} = \pi(0.06)^2 - \pi(0.025)^2 \text{ m}^2 \text{ (guess or measure)}$$

$$A_{CD} \sim 9 \times 10^{-3} \text{ m}^2$$

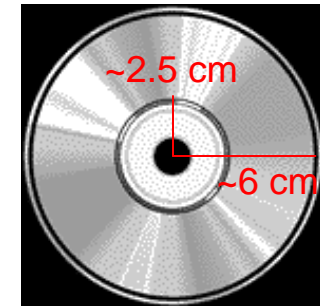

(2). Make your estimate!

Note dimensional consistency!

Area associated w/ each bit, $A_{bit} = A_{CD}/(\# \text{ of bits}) \sim 1.6 \times 10^{-12} \text{ m}^2/\text{bit}$

\Rightarrow Separation between each bit, $d \sim (A_{bit})^{1/2} \sim 1.3 \times 10^{-6} \text{ m} = 1.3 \text{ microns!}$

$\lambda = 0.65 \text{ microns}$



The benefit of using a blue-violet laser (405nm) is that it has a shorter wavelength than a red laser (650nm), which makes it possible to focus the laser spot with even greater precision. This allows data to be packed more tightly and stored in less space, so it's possible to fit more data on the disc even though it's the same size as a CD/DVD. This together with the change of numerical aperture to 0.85 is what enables Blu-ray Discs to hold 25GB/50GB.

Other resources on making estimates

A View From the Back of the Envelope
<http://www.vendian.org/envelope/>

University of Maryland Fermi Problems Site
<http://www.physics.umd.edu/perg/fermi/fermi.htm>

Old Dominion University Fermi Problems Site
<http://www.physics.odu.edu/~weinstei/wag.html>

Order of Magnitude Astrophysics
<http://www.astronomy.ohio-state.edu/~dhw/Oom/questions.html>

Back-of-the-Envelope Physics, Clifford Swartz (Baltimore, Johns Hopkins University Press, 2003).

The Back of the Envelope, E.M. Purcell, monthly column in the *American Journal of Physics*, July 1984 – Jan. 1993.

Consider a Spherical Cow : A Course in Environmental Problem Solving, John Harte (Berkeley, University Science Books, 1988).

Powers of Ten : About the Relative Size of Things in the Universe, and the Effect of Adding Another Zero, Philip Morrison and Phylis Morrison (Scientific American Library, 1982, 1994).

In-Class Activity Questions*

- (1). How much money did American consumers pay to fill up their cars with gas last year?
- (2). How many nails are needed to make sleeping on a bed of nails safe (but still crazy!)?
- (3). How much kinetic energy does the earth have due to its rotation about the sun? How much rotational kinetic energy does the earth have?
- (4). Legend has it that water in Southern Hemisphere washbasins drains in the opposite sense to that of water draining in Northern Hemisphere washbasins, i.e., that the Coriolis force, $|F_c| \sim 2m(\omega \times v)$ (where ω is the rotational frequency of the earth, v is the radial speed of the water, and m is the mass of the water), governs the behavior of draining water. Is this legend reasonable? (Hint: Compare your estimate of $|F_c|$ with another force in the problem, i.e., the gravitational force $F_{\text{grav}} = mg$.)
- (5). How fast does human hair grows (on average) in mph?
- (6). How much sand is there on all the beaches of the earth?

In-Class Activity Questions*

- (7). Estimate the surface area and volume of a typical human.
- (8). Estimate the number of cells in the human body.
- (9). Estimate the weight of earth's atmosphere. [Hint: Atmospheric pressure at sea level is ~ 14.7 psi]
- (10). In a letter to the Royal Society in 1774, Ben Franklin reported that the equivalent of 0.1 cm^3 of oil dropped on a lake spread to a maximum area of 40 m^2 . What is the thickness of the oil and does this make sense?
- (11). Estimate the number of leaves on a tree.
- (12). Estimate the weight of Mt. Everest [height $\sim 29,000$ ft].